

## Perturbation Method in the Analysis of Manipulator Inertial Vibrations

Przemysław SZUMIŃSKI  
*Division of Dynamics,  
Technical University of Łódź,  
Stefanowskiego 1/15, Łódź, Poland*

Received (10 June 2011)

Revised (12 June 2011)

Accepted (20 June 2011)

An analysis of inertial component of mechanical vibrations induced during a motion of the *MAR* industrial manipulator is presented. The mathematical analysis of vibrations is based on the perturbation method. The presented considerations include an analytical description of inertial vibrations as well as results of the numerical analysis for the *RPP*-type manipulator.

*Keywords:* Robot dynamics, perturbations, mechanical vibrations

### 1. Introduction

On one hand, manipulator structures should be light weighted also due to their drives, but on the other hand, velocities and accelerations achieved by links attain higher and higher values in subsequent manipulator designs [1, 3]. As a result, mechanical vibrations can be induced during motion. Simultaneously, the accuracy with which the gripping device follows the given motion trajectory belongs to basic characteristics of its quantitative evaluation [6, 10, 12]. Errors in following the motion trajectory by the gripping device depend on many factors, for instance the preciseness of the relative arrangement of links in kinematic pairs that results from the way the robot is controlled and driven, tolerance in the execution of individual element dimensions, elastic strains and clearances in kinematic pairs caused by errors in manufacturing, assembly and wear [2, 4, 5, 11]. The experimental measurement of link vibrations allows for a general analysis of vibration sources only [7, 8, 9]. A possibility to describe the components of link vibrations from the viewpoint of their sources is essential. However, analytical descriptions of mutual relations between components of the vibrations induced by various sources can be hardly found in the literature.

## 2. Perturbation analysis of vibrations

The equations of perturbations of the manipulator nominal motion are based on equations of the manipulator dynamics [14]

$$[M] \cdot [\ddot{q}_m] + [C] \cdot [\dot{q}_m] + [K] \cdot [q_m] + [G] = [Q] \quad (1)$$

where:

- [ $M$ ] – matrix of the manipulator inertia;
- [ $D$ ] – matrix of the energy dissipation in driving systems;
- [ $C$ ] – matrix of effects of gyroscopic, centrifugal and Coriolis forces;
- [ $G$ ] – column matrix of gravity forces; [ $K$ ] – matrix of stiffness of driving systems;
- [ $Q$ ] – column matrix of generalized driving quantities;
- [ $x$ ] – column matrix of generalized coordinates of the manipulator.

Let us introduce a nominal motion disturbance  $x_n$  in the form

$$x = x_n + \Delta x \quad (2)$$

where  $x$  denotes displacement (angular or linear) of the link and its derivatives with respect to time,  $x_n$  – generalized coordinate of the nominal motion and its derivatives,  $\Delta x$  refers to a perturbation of the nominal value of the generalized coordinate and its derivative. We assume slight perturbations of the nominal motion. Now let us describe the link perturbation  $\Delta x$  as

$$\Delta x = x_1 + x_2 \quad (3)$$

where  $x_1$  denotes a perturbation of the nominal motion resulting from inertial vibrations of the link and  $x_2$  denotes a perturbation of the link motion resulting from the perturbation occurring in the driving system.

$$\begin{aligned} & [M(x_n + \Delta x)][\ddot{x}_n + \Delta\ddot{x}] + [D][\dot{x}_n + \Delta\dot{x}] + [K][x_n + \Delta x] \\ & + [C(x_n + \Delta x, \dot{x}_n + \Delta\dot{x})] + [G(x_n + \Delta x)] = [Q_n + \Delta Q] \end{aligned} \quad (4)$$

Introducing inertial perturbations of links and perturbations in driving systems into equations (1), the following equations have been obtained

In Eqs. (4), trigonometric functions of variables  $\Delta x$  have been expanded into power series, and then linearization through rejection of terms in the power series that are terms of the higher order has been conducted. Slight perturbations of the nominal motion are assumed. The equations of manipulator perturbations take then the following form

$$\begin{aligned} & [\underline{M}(x_n)][\Delta\ddot{x}] + [\underline{D}(x_n, \dot{x}_n)][\Delta\dot{x}] + [\underline{K}(x_n, \dot{x}_n, \ddot{x}_n)][\Delta x] \\ & + [\underline{G}(x_n, \dot{x}_n, \ddot{x}_n, \Delta x, \Delta\dot{x}, \Delta\ddot{x})] + \underline{N}[x_n, \dot{x}_n, \ddot{x}_n] = [Q_n + \Delta Q] \end{aligned} \quad (5)$$

The analysis of vibration sources can concern a case when  $x_1$  in equation (5) is equal to zero or when  $x_2$  is equal to zero. Links of the manipulator that performs

repeatable technological tasks move periodically. During such a motion, links can change their velocity, stop and start moving again. In the case when  $x_2$  is equal to zero then Eq. (5) describes vibrations of inertial nature that originate in changes of accelerations of links. The inertial vibrations can be described as

$$\begin{aligned}
 & [A(x_n)]\ddot{x}_1 + [B(x_n, \dot{x}_n)]\dot{x}_1 + [C(x_n, \dot{x}_n, \ddot{x}_n)]x_1 \\
 & + [Z(x_n, \dot{x}_n, \ddot{x}_n, x_1, \dot{x}_1, \ddot{x}_1)] = 0
 \end{aligned}
 \tag{6}$$

By the numerical integration of equation (6) we can obtain the characteristic curves of inertial component of link mechanical vibrations.

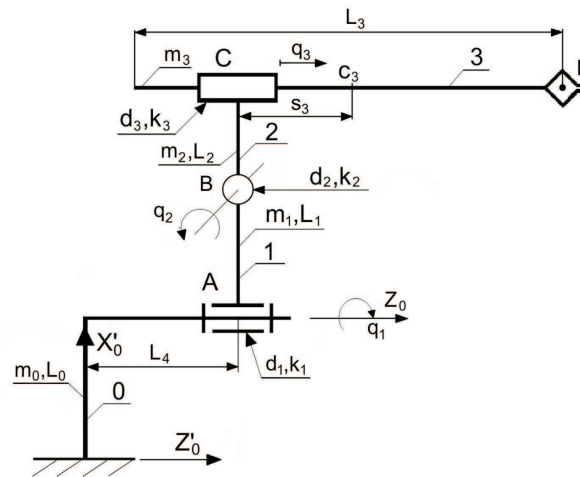

Figure 1 Kinematic scheme of the MAR manipulator.

### 3. Model of the MAR manipulator

A MAR manipulator, Fig. 1, has been subjected to analysis of mechanical vibrations. This is a modular robot with three degrees of freedom. The MAR manipulator is designed to displace continuously and repeatably tiny objects on the assembly, processing, control stands and to perform short-distance transportation activities. The MAR manipulator is a robot with a constant working cycle. In Tab. 1, the MAR manipulator main data are presented.

A vector of generalized coordinates of the manipulator is

$$\bar{q} = [q_1, q_2, q_3]^T
 \tag{7}$$

The energy of dissipation of the kinematic pair has been expressed by means of a resultant coefficient of energy dissipation as a function of square relative velocity

**Table 1**

Number of the link	1	2	3
Length of the link [m]	0.15	0.18	0.42
Mass of the link [kg]	12.7	12.7	15
Static stiffness [Nm/rad, N/m]	110066	110066	1604648
Damping [Nms/rad], [Ns/m]	95	76	246
$S_3 = 0.18$ m			

of kinematic pair links. The electric and mechanical model of the driving system covers torsional flexibilities and viscous damping. It has been assumed that each link is driven by an independent driving system and consists of an electric motor, a mechanical gear and driving shafts.

The general equations of the *MAR* manipulator motion are as follows

$$[M] \cdot [\ddot{q}_m] + [C] \cdot [\dot{q}_m] + [K] \cdot [q_m] + [G] = [Q] \quad (8)$$

where

$[M]$  – matrix of inertia of the manipulator,

$[K]$  – matrix of stiffness;

$[C]$  – matrix of effects of gyroscopic forces, centrifugal forces and Coriolis forces,

$[G]$  – matrix of gravity forces,

$[Q]$  – matrix of driving quantities,

$[q]$  – matrix of generalized coordinates of the manipulator.

The manipulator performs its technological task in two steps. The first one means a motion in the first driving system and the second one a motion of the second and third degree of freedom, whereas the first degree is stationary. The presented analysis concerns the second step of motion.

### 3.1. Inertial component of vibrations of the *MAR* manipulator

During the second step of motion of the *MAR* manipulator, after introducing perturbations of second and third generalized coordinates, we receive equations of links vibrations. The inertial vibrations, Eq. (6), have the form

$$[A][\ddot{x}_1] + [B][\dot{x}_1] + [C][x_1] + [Z] = 0 \quad (9)$$

where

$$[A] = \begin{bmatrix} \frac{1}{3}m_2L_2^2 + m_3 \left[ \frac{1}{12}L_3^2 + L_2^2 + (s_3 + q_3)^2 \right] & -m_3L_2 \\ -m_3L_2 & m_3 \end{bmatrix}$$

$$[B] = \begin{bmatrix} 2m_3\dot{q}_3(s_3 + q_3) + c_2 & 2m_3\dot{q}_2(s_3 + q_3) \\ -2m_3\dot{q}_2(s_3 + q_3) & c_3 \end{bmatrix} \quad (10)$$

$$[C] = \begin{bmatrix} -[m_3(s_3 + q_3) \sin(q_2) & m_3\{2[(s_3 + q_3)\ddot{q}_2 + \dot{q}_2\dot{q}_3] \\ + (m_3 + \frac{1}{2}m_2)g \cos(q_1) \cos(q_2)]L_2 \cos(q_2)] & +g \cos(q_1) + k_2 \\ m_3g \cos(q_1) \cos(q_2) & k_3 - m_3\dot{q}_2^2 \} \end{bmatrix}$$

$$[Z] = \begin{bmatrix} \ddot{q}_2\{\frac{1}{3}m_2L_2^2 + m_3[L_2^2 + \frac{1}{12}L_3^2 + (s_3 + q_3)^2 + x_{13}^2]\} - m_3L_2\ddot{q}_3 \\ + 2m_3[(s_3 + q_3)(\dot{q}_2\dot{q}_3 + \dot{x}_{12}x_{13} + \dot{x}_{12}\dot{x}_{13}) + x_{13}(\dot{q}_2\dot{x}_{13} + \dot{q}_3\dot{x}_{12})t] \\ - \{\frac{1}{2}m_2L_2 \sin(q_2) + m_3[(L_2 + x_{12}x_{13}t) \sin(q_2) \\ - (s_3 + q_3) \cos(q_2)]t\}g \cos(q_1) \\ m_3 [\ddot{q}_3 - L_2\ddot{q}_2 - (s_3 + q_3)(\dot{q}_2^2 + \dot{x}_{12}^2) - 2\dot{q}_2x_{13}\dot{x}_{12} + g \cos(q_1) \sin(q_2)] \end{bmatrix}$$

$c_i, k_i$  – coefficients of damping and dynamic stiffness of the  $i$ -th driving system, Tab. 1.

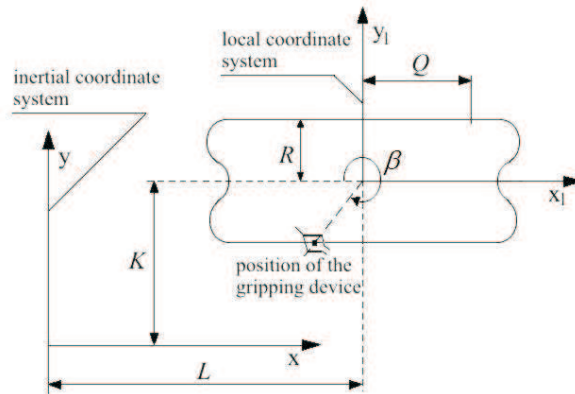

**Figure 2** Parameters of the trajectory of the gripping device motion

### 3.2. Trajectory of the gripping device motion

The trajectory of the manipulator gripping device motion is presented in Fig. 2. This is a flat motion trajectory described with a combination of trigonometric functions. A detailed mathematical description of the trajectory is to be found in [13].

The geometrical data of the gripping device trajectory can be found in Tab. 2.

**Table 2**

Parameters of the trajectory of motion	Q [m]	L [m]	K [m]	R [m]
-	0.05	0.35	0.05	0.05

The assumed trajectory shows a possibility of occurrence of manipulator stops and start-ups, Fig. 3. The position of the gripping device on its trajectory is described by an angle  $\beta$  in the local coordinate system  $X_1Y_1O_1$ , see Fig. 2.

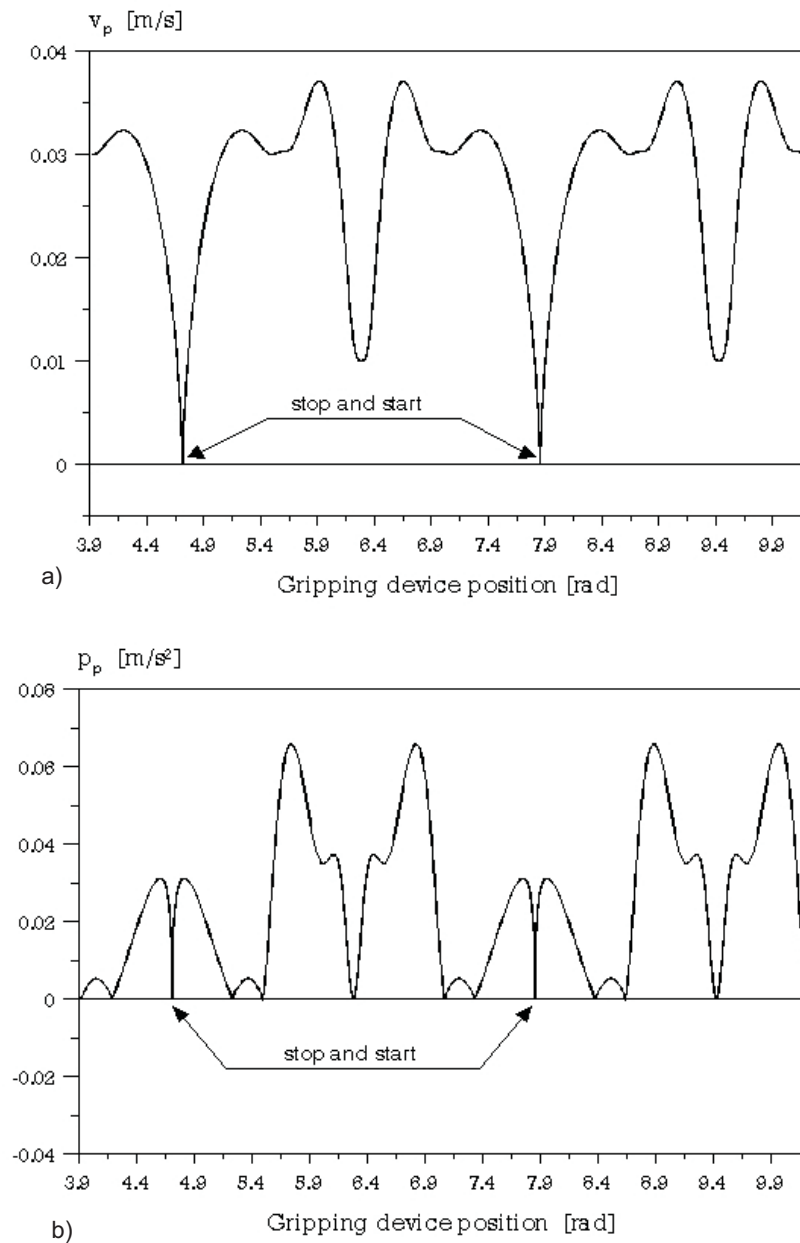

**Figure 3** Velocity and acceleration of the gripping device as a function of the angle  $\beta$

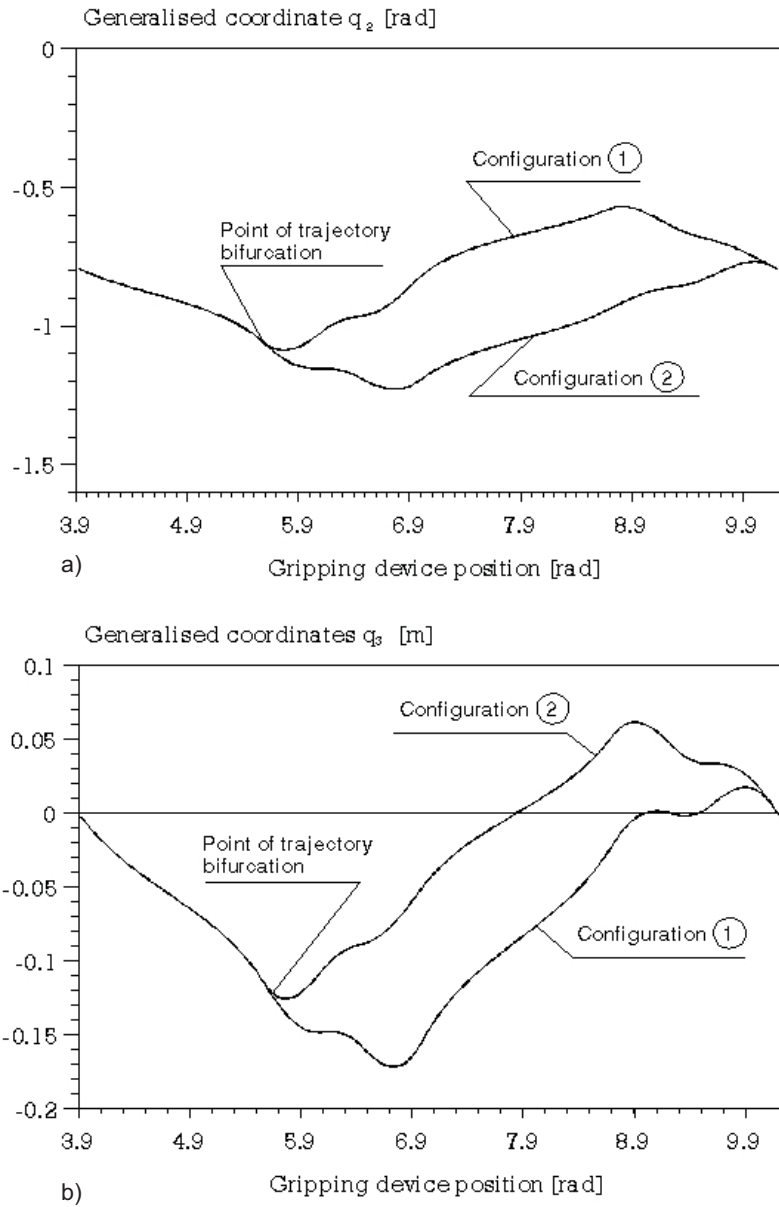

Figure 4 Generalized coordinates  $q_2$  and  $q_3$  as a function of the angle  $\beta$

### 3.3. Reverse task of kinematics and dynamics of the MAR mManipulator

For the proposed analysis of manipulator mechanical vibrations, it is necessary to solve reverse tasks of kinematics and dynamics [3, 10–12]. The kinematics reverse task allows us to determine generalized coordinates, their velocities and accelerations as a function of the gripping device position. A solution to the kinematics reverse task of the MAR manipulator can be found in [13]. On the other hand, the reverse task in dynamics allows for calculating values of forces and driving moments for the imposed trajectory of the gripping device motion. The Newton–Euler method [10] was used to solve the dynamics tasks. The velocity and acceleration of the gripping device are presented in Fig. 3.

The generalized coordinates of the manipulator and the generalized driving quantities of the nominal motion, for the configuration under consideration, are presented in Figs 4, 5.

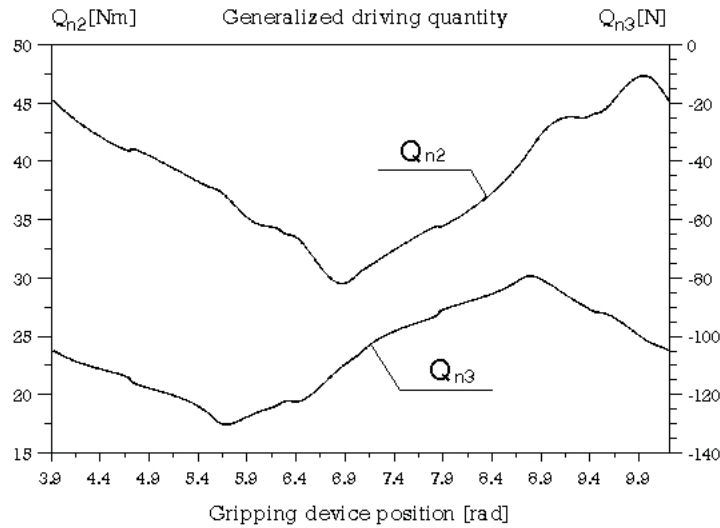

Figure 5 Generalized driving quantities of the nominal motion

Table 3

Parameter	Second gear	Third gear
Radius of the gear $r_1$ [m]	0.016	0.016
Radius of the gear $r_2$ [m]	0.02	0.02
Radius of the gear $r_3$ [m]	-	0.03
Length $a, b, c$ [m]	0.025	0.025
Mechanical ratio $n_i$ [-]	0.8	0.8
Rolling bearings $SKF$ [15]	7200B	7200B



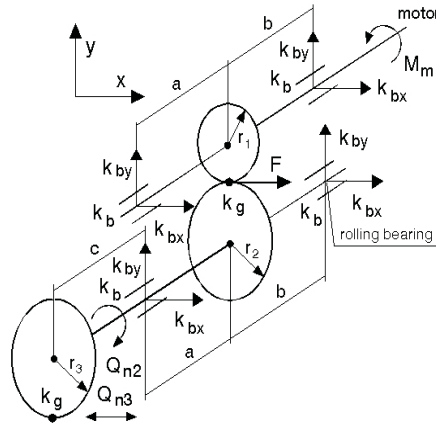

Figure 6 Scheme of mechanical gears

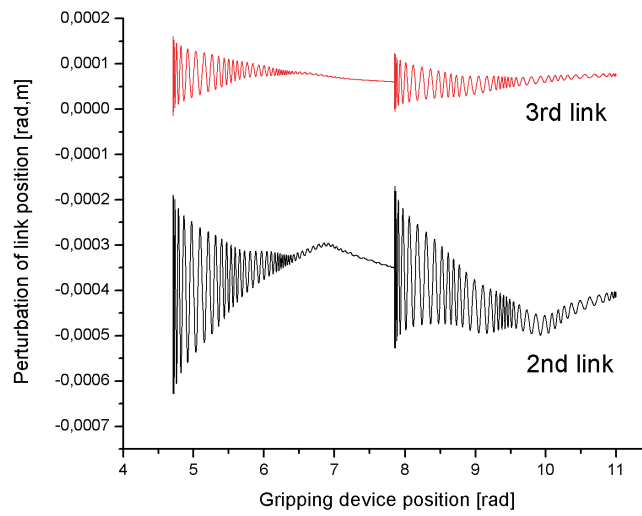
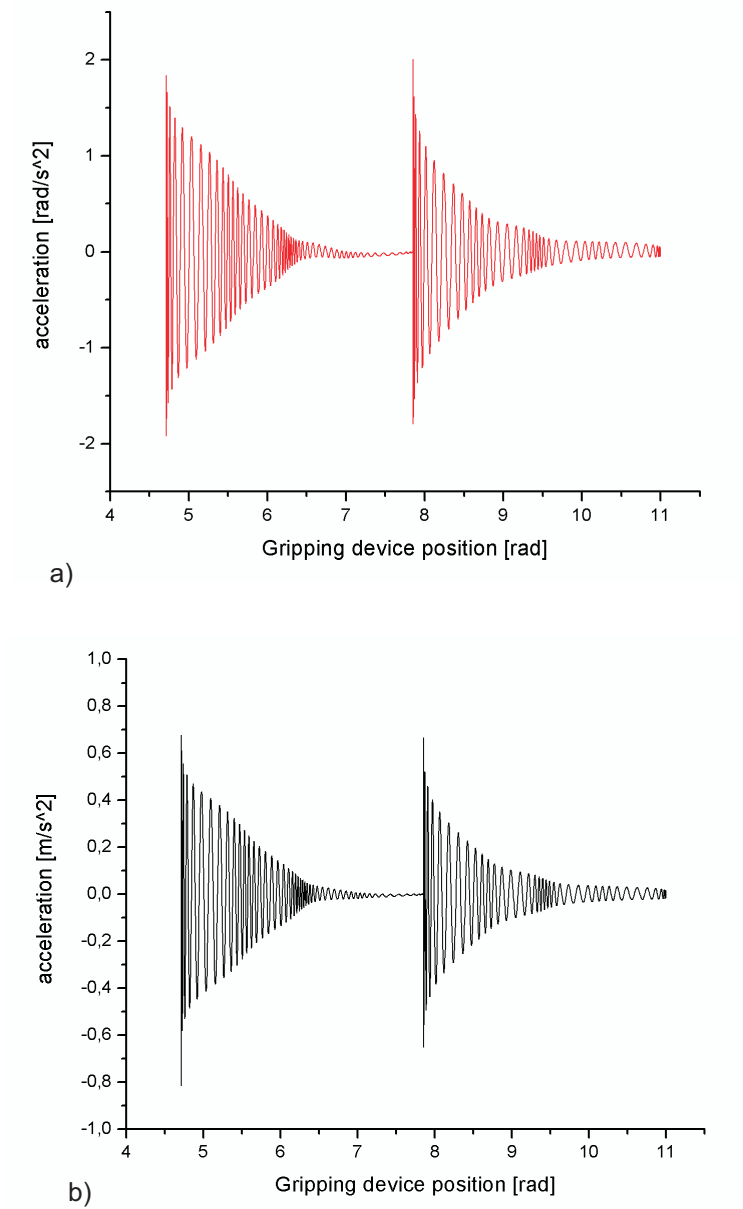

Figure 7 Perturbations of the links position due to the links motion

#### 4. Numerical analysis of inertial vibrations of the MAR robot

The numerical analysis is aimed at an analysis of inertial vibrations. The analysis takes into account stiffnesses of rolling bearings of the driving system, Fig. 6. Main data of the driving systems can be found in Tab. 3. A model of analysis of stiffness of manipulator rolling bearings and bearing systems is to be found in [14]. This algorithm has been applied in calculations of stiffness of individual bearings and



**Figure 8** Accelerations of vibrations of the links due to the links motion, a)  $2^{nd}$  link, b)  $3^{rd}$  link

then bearing systems occurring in driving systems, Fig. 6. Figs 7 and 8 show perturbations of links position and accelerations of inertial vibrations.

## 5. Conclusions

In the paper, an analysis of vibrations due to the motion of the linkage mechanism itself is presented. The presented method for analysis of mechanical vibrations allows for a mathematical description of components of links vibrations. As an example, a three-degree-of freedom manipulator has been analyzed to show and solve numerically the problem. The plots presented allow for an evaluation of sources of mechanical vibrations in the working space of the robot. The experimental results obtain can be employed by designers to improve an accuracy of the robot positioning.

## References

- [1] **Eschmann, P. and Hasbargen, L.:** Ball and roller bearings – theory design and application, *Willey & Sons*, New York, **1999**.
- [2] **Hać, M. and Osiński, J.:** Stability analysis of parametric vibration of flexible mechanisms, *Machine Dynamics Problems*, **3**, 135–146, **1992**.
- [3] **Jeziński, E.:** Dynamics of robots, *Scientific-Technical Publisher*, Warsaw, (*in Polish*), **2006**.
- [4] **Knapczyk, J. and Lebediew, P.A.:** Theory of 3D mechanisms and manipulators, *Scientific-Technical Publishers*, Poland, (*in Polish*), **1990**.
- [5] **Kozłowski, K., Dutkiewicz, P. and Wróblewski, W.:** Modeling and control of robots, *State Scientific Publishers*, Warsaw, (*in Polish*), **2003**.
- [6] **Kucharski, T.:** Mechanical vibrations, *Scientific-Technical Publishers*, Warsaw, (*in Polish*), **2004**.
- [7] **Lisowski, W., Giergiel, J. and Uhl, T.:** Application of modal models for vibration control of manipulators, *Proceedings of Noise Control*, AGH Cracow, 73–78, **1992**.
- [8] **Liu, Y.C. and Yang S.M.:** Vibration control experiment of a slewing flexible beam, *ASME J. of Dynamic Sys., Measur., Control*, 117, 431–435, **1995**.
- [9] **Morecki, A. and Knapczyk, J.:** Foundations of robotics, theory and elements of manipulators and robots, *Scientific-Technical Publishers*, Warsaw, (*in Polish*), **1999**.
- [10] **Sciavicchio, L. and Siciliano, B.:** Modeling and control of robot manipulators, *Springer*, London, **2000**.
- [11] **Spong, M.W. and Vidyasagar, M.:** Robot dynamics and control, *J. Wiley & Sons*, New York, **1989**.
- [12] **Stępniewski, A.:** Effect of the manipulator driving system flexibility on accuracy of the trajectory representation, *XIV TMM Polish Scientific and Didactic Conference*, 147–152 (*in Polish*), **1994**.
- [13] **Szumiński, P. and Kapitaniak, T.:** Stability regions of periodic trajectories of the manipulator motion, *Chaos, Solitons and Fractals*, 17, 67–78, **2003**.
- [14] **Szumiński, P.:** Determination of the stiffness of rolling kinematic pairs of manipulators, *Mechanism and Machine Theory*, 42(9), 1082–1102, **2007**.
- [15] SKF catalogue of rolling bearings.

