

CONTROL OF A DC MOTOR USING RELAYS, TRANSISTORS, AND AN H-BRIDGE

International Faculty of Engineering – BASIC ELECTRICITY – Exercise 23 *

1 Aim of the exercise

The aim of this laboratory exercise is to introduce the basic principles of DC motor operation and control. The structure and operating principle of a small DC motor are examined experimentally, together with several commonly used motor control methods. The operation of relay-based control, transistor switching, pulse-width modulation (PWM) speed control, and bidirectional control using an H-bridge circuit is investigated. The influence of the applied control method on the motor direction and rotational speed is observed and analyzed.

2 Theoretical introduction

2.1 Principle of operation of a DC motor

A DC motor is an electrical device that converts electrical energy into mechanical rotational motion. Its operation is based on the interaction between a magnetic field and an electric current flowing through a conductor. When a current-carrying conductor is placed in a magnetic field, a force acts on it according to the Lorentz force principle. The direction of this force is always perpendicular both to the current direction and to the magnetic field direction. In a DC motor, this force produces a torque that causes the rotor to rotate, Fig. 1 ¹.

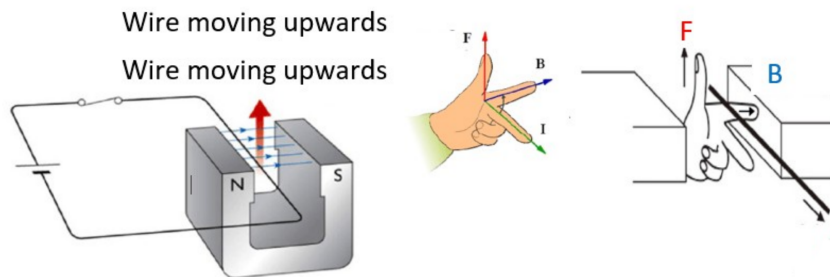

Figure 1: Lorentz force acting on a current-carrying conductor in a magnetic field

The magnitude of the Lorentz force acting on a straight conductor can be expressed as:

$$F = BIl \sin(\theta)$$

where:

- F – force acting on the conductor,
- B – magnetic flux density,

* Author: M. Balcerzak, Łódź 2026

¹<https://app.pandai.org/note/read/kssm-ph-11-04-01/KSSM-F5-PH-04-01>

- I – current flowing through the conductor,
- l – length of the conductor placed in the magnetic field,
- θ – angle between the current direction and the magnetic field.

The force reaches its maximum value when the conductor is perpendicular to the magnetic field ($\theta = 90^\circ$).

A simple brushed DC motor consists of several main components, see Fig. 2:²

- the **stator**, which generates a stationary magnetic field (using either permanent magnets or electromagnets),
- the **rotor (armature)**, containing wire windings through which the current flows,
- the **commutator**, which periodically reverses the direction of current in the rotor windings,
- the **brushes**, which provide electrical contact between the stationary power supply and the rotating commutator.

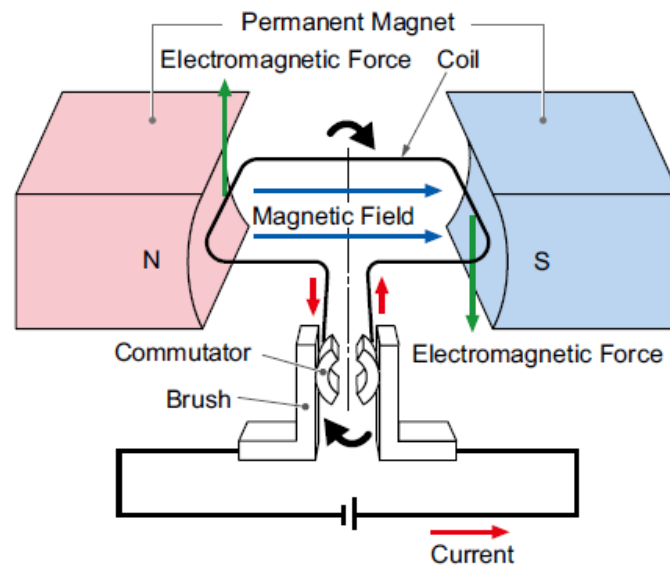

Figure 2: A simplified model of a brushed DC motor

As the rotor turns, the commutator continuously switches the current direction in the rotor windings. This ensures that the generated torque remains in the same rotational direction, allowing continuous rotation of the motor shaft.

The torque generated by a DC motor is approximately proportional to the current flowing through the rotor windings:

$$T \propto I$$

where:

- T – motor torque,
- I – armature current.

²<https://blog.orientalmotor.com/technical-manual-series-brushless-motor-structure-and-principles>

At the same time, the rotating motor generates a voltage called the back electromotive force (back EMF), which opposes the applied supply voltage. The back EMF increases with rotational speed:

$$E_{\text{back}} \propto \omega$$

where:

- E_{back} – back electromotive force,
- ω – angular velocity of the motor.

As a result, the motor current is highest during startup and decreases as the rotational speed increases.

In practice, real DC motors contain many rotor windings distributed around the armature, rather than a single current loop. This design provides smoother rotation, more stable torque, and improved efficiency. Practical motors also include additional mechanical components such as bearings, a housing, cooling elements, and permanent magnets or electromagnets optimized for efficient operation. Consequently, the internal construction of a real motor is more complex than the simplified schematic diagrams typically used to explain the basic operating principle, Fig. 3 (left)³ and (right)⁴.

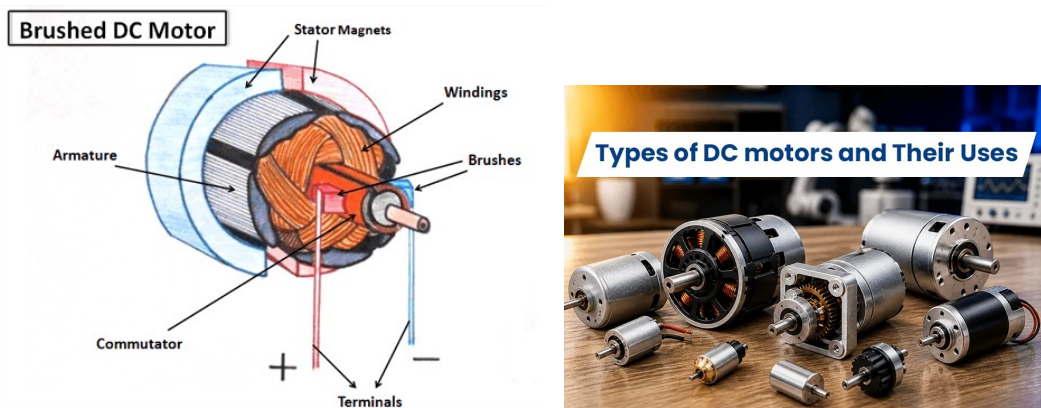

Figure 3: Practical construction of a DC motor; left – schematic diagram, right – photograph

The rotational speed and direction of a DC motor can be controlled by modifying the applied voltage and current direction, which forms the basis of the control methods investigated in this laboratory exercise.

2.2 DC motor control using a relay

One of the simplest methods of controlling a DC motor is the use of an electromechanical relay. A relay is an electrically controlled switch that allows a low-power control circuit to switch a higher-power load, such as a motor. A typical relay consists of a coil, a movable armature, and electrical contacts. When current flows through the relay coil, a magnetic field is generated, attracting the armature and changing the state of the contacts. In this way, the motor power supply can be connected or disconnected without direct mechanical switching by the user, Fig. 4⁵.

³<https://cecas.clemson.edu/cvel/auto/actuators/motors-dc-brushed.html>

⁴<https://business.moglix.com/blogs/what-are-the-different-types-of-dc-motors-importance-and-uses>

⁵<https://www.build-electronic-circuits.com/how-a-relay-works/>

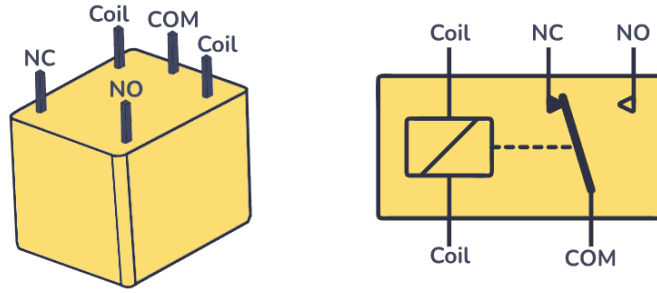

Figure 4: Schematic diagram of a relay

In the simplest motor control circuit, the relay acts as an on/off switch connected in series with the motor and the power supply. When the relay contacts are closed, current flows through the motor and the rotor begins to rotate. When the contacts are opened, the current flow stops and the motor slows down due to friction and mechanical load, Fig. 5⁶



Figure 5: Schematic diagram of a relay

Although the relay provides simple and effective switching, important transient phenomena occur during switching operations. A DC motor is an inductive load because its windings store energy in a magnetic field. When the current flowing through the motor is suddenly interrupted, the collapsing magnetic field generates a voltage spike according to Faraday's law of electromagnetic induction. This effect can be approximately described by:

$$u_L = L \frac{di}{dt}$$

where

- u_l – voltage generated by the inductance,
- L – inductance.

A rapid decrease in current produces an enormous value of the current time derivative di/dt , and thus a large voltage spike, which may cause electrical arcing at the relay contacts, electromagnetic interference, or even damage to electronic components. To reduce these effects, protective elements are commonly used. In DC motor circuits, a flyback diode connected in parallel with the motor is often applied. The diode provides an alternative path for the current generated during switching-off, reducing the voltage spike and protecting the relay contacts and other components, Fig. 6⁷.

⁶<https://forum.arduino.cc/t/do-a-12v-dc-motor-achieve-its-full-efficiency-when-connected-to-a-5v-relay/666658>

⁷<https://www.kynix.com/Blog/flyback-diode-flywheel-diode-applications.html>

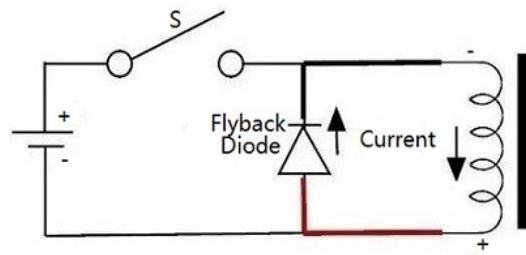

Figure 6: Circuit with inductance secured by a flyback diode

Because relays contain moving mechanical parts, their switching speed is relatively low and their lifetime is limited by mechanical wear and contact degradation. For this reason, transistor-based motor control methods are commonly used in modern electronic systems.

2.3 DC motor control using a bipolar transistor, PWM and an H-Bridge

In modern electronic systems, DC motors are commonly controlled using semiconductor devices such as transistors. Compared to relays, transistor-based control provides much faster switching, silent operation, higher reliability, and efficient speed regulation. One of the simplest electronic motor drivers uses a bipolar junction transistor (BJT) operating as an electronic switch. In this configuration, the motor is connected in series with the transistor and the power supply, see Fig. 7⁸.

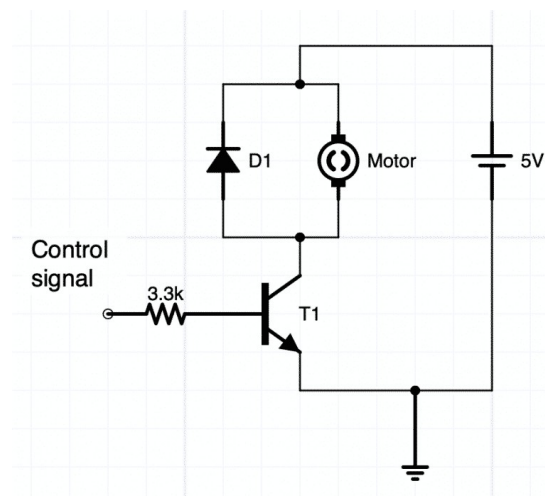

Figure 7: DC motor controlled by an NPN bipolar transistor

A bipolar transistor has three terminals:

- the base (B),
- the collector (C),
- the emitter (E).

In an NPN transistor, a small current flowing into the base controls a much larger current flowing from the collector to the emitter. When sufficient base current is applied, the transistor enters the saturation region and behaves approximately like a closed switch, allowing current to flow through the motor. When the base current is removed, the transistor switches off and the

⁸<https://techexplorations.com/guides/arduino/motors/dc-motor-with-transistor/>

motor current stops. Because the motor current may be much larger than the current available from a control circuit or microcontroller output, the transistor allows low-power control signals to operate higher-power loads.

The rotational speed of the motor can be controlled efficiently using Pulse-Width Modulation (PWM). In PWM control, the transistor is switched on and off rapidly at a constant frequency. As a result, the motor receives a sequence of voltage pulses rather than a continuously varying voltage, Fig. 8⁹.

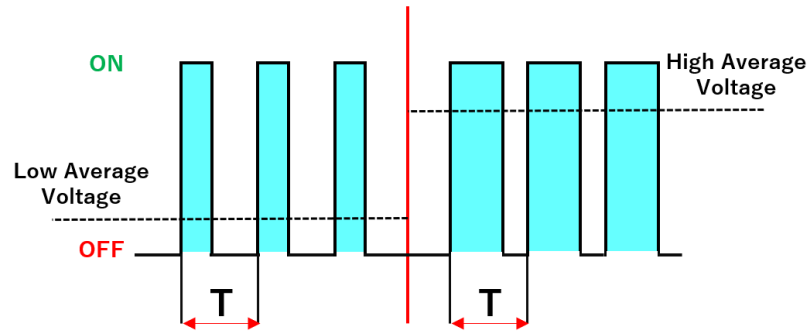

Figure 8: PWM signal with low and high duty cycle

The average voltage applied to the motor depends on the duty cycle of the PWM signal, defined as:

$$D = \frac{t_{ON}}{T}$$

where

- D – duty cycle,
- t_{ON} – time during which the transistor is switched on,
- T – signal period.

Increasing the duty cycle increases the average motor voltage and therefore increases the rotational speed. Decreasing the duty cycle reduces the speed. Because the transistor switches between nearly fully ON and fully OFF states, PWM control is significantly more energy-efficient than controlling the speed using a variable resistor or linear voltage regulation.

As in relay-controlled circuits, the motor acts as an inductive load. Consequently, a flyback diode connected in parallel with the motor is required to protect the transistor from voltage spikes generated during switching.

In the single-transistor configuration, the current always flows through the motor in the same direction. Consequently, the motor can rotate only in one direction. **To reverse the rotational direction of a DC motor, the polarity of the applied voltage must be reversed. This is achieved using a circuit called an H-bridge.**

⁹<https://leecuriosity.com/understanding-pulse-width-modulation-pwm/>

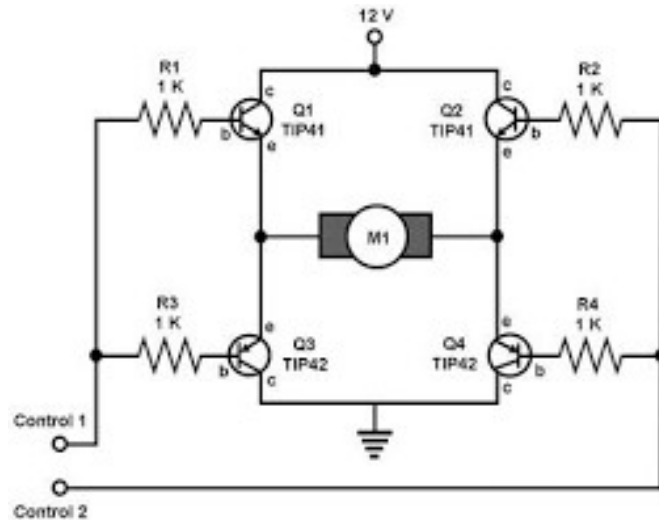

Figure 9: Schematic diagram of an H-bridge motor driver

An H-bridge consists of four switching elements (typically transistors) arranged in a configuration resembling the letter “H”. By activating different pairs of switches, the direction of current flowing through the motor can be changed. As a result, the motor can rotate both clockwise and counterclockwise. The H-bridge also allows PWM speed control in both rotational directions, making it one of the most commonly used DC motor control methods in robotics, automation, and embedded systems, see Fig. 9.¹⁰

3 Procedure of the experiment

- Familiarize yourself with the construction of the DC motor used in the experiment. Identify the main components of the motor, including the stator, rotor, commutator, and brushes. Discuss their functions and the general operating principle of the motor.
- Connect the DC motor directly to a 5V power supply. Measure the current drawn by the motor under no-load conditions and observe the rotational behavior of the motor.
- Assemble a relay-based motor control circuit in which the relay is activated using a push button.
- Use the oscilloscope to observe the voltage across the motor terminals during switching operations. In particular, observe the voltage spikes generated when the relay disconnects the motor supply.
- Connect a flyback diode in parallel with the motor and repeat the oscilloscope measurements. Compare the observed waveforms and discuss the influence of the diode on the transient voltage spikes.
- Assemble a transistor-based motor driver using a bipolar NPN transistor and a flyback diode. Connect the control input to an Arduino PWM output.
- Generate a PWM control signal using the Arduino and investigate the influence of the duty cycle on the motor rotational speed. Observe the PWM waveform using the oscilloscope and compare the motor behavior for different duty cycle values.

¹⁰<http://electronic-projects.50webs.com/transistor-based-dc-motor-controller--single-supply-.htm>

- Using the transistor-based PWM driver, investigate the relationship between the PWM duty cycle, the average motor voltage, and the rotational speed of the motor. Measure the rotational speed using a stroboscope or optical tachometer and prepare a plot of rotational speed versus average voltage.
- Assemble an H-bridge motor driver circuit connected to the Arduino.
- Use the H-bridge to control the motor in both rotational directions by changing the polarity of the applied voltage. Investigate the influence of PWM duty cycle on the motor speed for both directions of rotation.
- Compare the investigated control methods (relay, single-transistor PWM control, and H-bridge control) in terms of functionality, switching behavior, speed control capability, and direction control.

**LABORATORY
OF
TECHNICAL MECHANICS**

Exercise 23

**CONTROL OF A DC MOTOR USING RELAYS,
TRANSISTORS, AND AN H-BRIDGE**

Group: _____ **date** _____ **Name**
Team: _____

and surname:

1. _____
2. _____
3. _____
4. _____
5. _____
6. _____

Speed-voltage characteristic of the motor

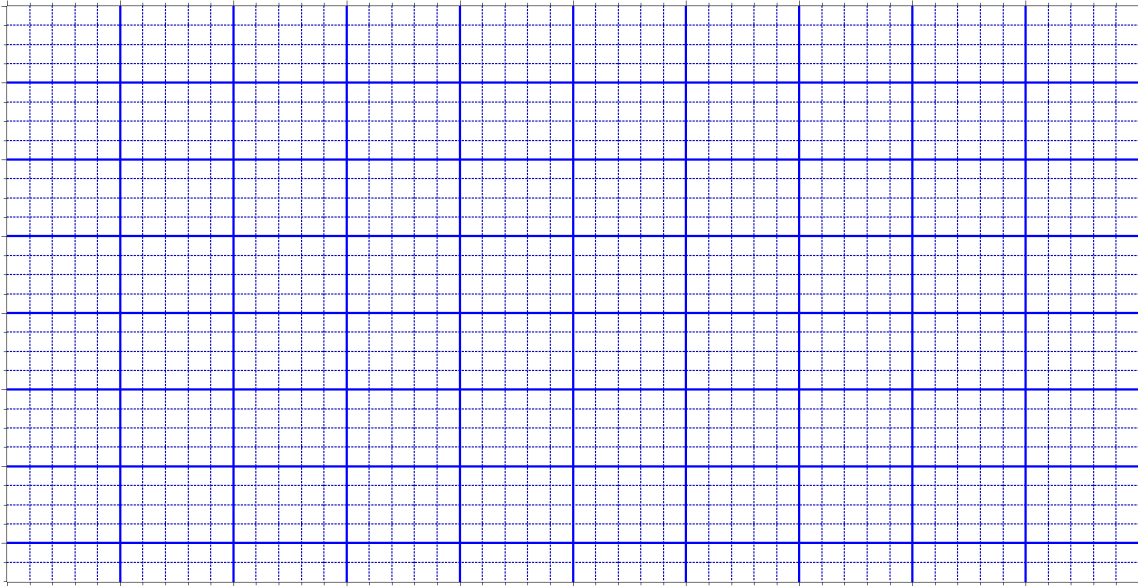

PWM signal at the transistor base and across the moto

