

DETERMINATION OF FORCES IN THE TRUSS MEMBERS

International Faculty of Engineering - BASIC MECHANICS – Exercise 2 *

1 Aim of the experiment

The aim of the test is to determine forces in the members of the plane truss experimentally using a strain-gauge measurements technique and by analytical method of joints and method of sections.

2 Theoretical backgrounds

A truss is a system of straight members whose ends are connected by pins. Trusses are widespread engineering structures (bridge spans, electric traction poles, various types of girders, jibs, crane beams, etc.). A distinction is made between flat trusses (all members lie in one plane) and spatial trusses.

In real structures, member connections are made using welding, riveting, bolting, etc. In the calculations of such structures, the nodes are assumed to be pinned connections, which significantly simplifies the analysis. An additional simplification is the omission of the weight of the members in the calculations. The laboratory setup allows for the experimental determination of forces in the truss members. Comparing the results obtained from measurements with the results of theoretical calculations for the physical model of the truss allows for the verification of the adopted model.

2.1 Forces in members of the truss

From a practical perspective, it is important to determine the reaction forces of the supports and the forces acting in the members. To determine the reactions, the equilibrium conditions of the entire truss (any plane force system) are used. Once these reactions are determined, the internal forces in the members can be determined. Several methods are used to determine the forces in the truss members, including:

1. Nodal equilibrium method: involves freeing individual truss nodes from constraints and composing equilibrium equations separately for each node (projecting all acting forces onto two arbitrary, non-parallel axes).
2. Ritter's method: allows for the determination of forces in selected members. In this case, the equilibrium of one of two subsystems obtained from a mental intersection of the truss is considered. The section is drawn through a maximum of three members, provided that their axes do not coincide.
3. Computer methods: are used to solve trusses with a large number of members. The procedures used for this purpose enable numerical and sometimes analytical solutions.

The truss consists of straight slender members connected at joints. In the case of a simple truss, we have the following condition for its proper rigidity (the truss will not collapse – is not a mechanism):

$$p = 2w - 3 \quad (1)$$

where p is the total number of truss members and w is the total number of joints.

Loads must be applied to the joints only, and not to the members themselves. In the analysis of the truss, the weights of bars are either omitted or, if required, they are applied to the joints (a half of the weight to each of the bar joints).

The truss presented in Fig. 1 is a plane structure made of $p = 13$ members, $w = 8$ joints and 3 supporting bars (these are not truss members). If a load is applied at arbitrary joints, the internal forces in the truss members and in the supporting bars (reactions) occur. Such truss may be considered as a set of two-force members pin-jointed at their ends. The forces in all bars can be determined considering successively the equilibrium of each joint. There are $p + 3$ equations available for p members and 3 reactions. This method of joints is most effective when the forces in all the members are to be determined.

* Author: W. Lubnauer, in – K. Januszkiewicz, J. Grabski: ĆWICZENIA LABORATORYJNE Z MECHANIKI, Łódź 2008

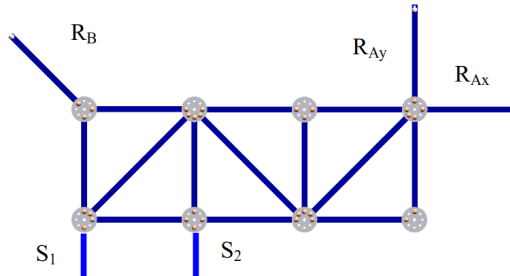

Figure 1: Plan truss

Such a truss can be considered as a set of two members pinned together at their ends. The forces in all members can be determined by considering the equilibrium of each node in turn. The equations $p + 3$ are available for p members and three reactions. This connection method is most effective when forces in all members must be determined.

If the force in only one member or several members needs to be determined, the cross-section method is more efficient. In this method, the equilibrium of a large section of the truss, consisting of several nodes and elements separated from the structure by an imaginary cross-section, must be analyzed. This cross-section must intersect a maximum of three members, allowing for the calculation of three unknowns for a two-dimensional force system. In this case, three equations are available (treating the entire truss as a free body, we have three additional equations to determine the reactions, if necessary). Solving the problem can be accelerated by eliminating the so-called zero members from the truss. Fig. 2 shows two cases of the zero-bar arrangement occurring in a flat truss. It should be noted, however, that such members are not useless, they are needed to secure the stability of the truss structure under self-weight or if the loading conditions are changed for example.

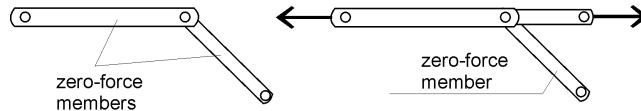

Figure 2: Examples of rope-and-pulley arrangements

If the force in only one member or the forces in few members are to be determined, the method of section is more efficient. In this method, we analyze the equilibrium of a large portion of the truss, composed of several joints and members separated from the structure by an imaginary section. This section must cut maximum three members thus allowing the calculation of three unknowns for 2-D force system. In this case there are 3 equations available (considering the entire truss as a free body, we have in addition 3 equations to determine the reactions if necessary).

2.2 Rope-and-pulley arrangements

Their main purpose is to transmit and modify input force P into the output force Q . Several rope-and-pulley arrangements are shown in Fig. 3.

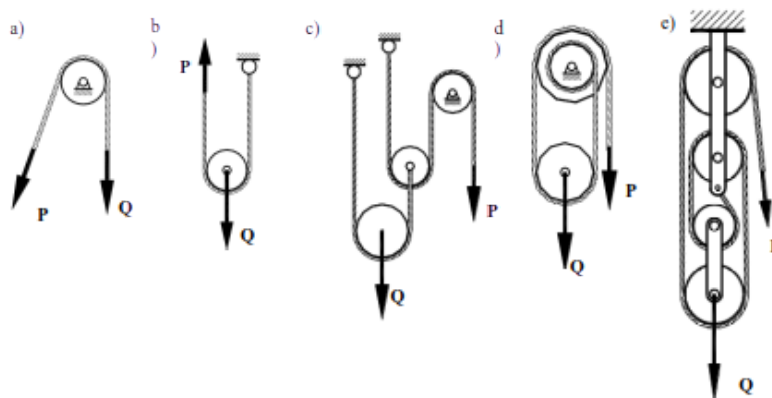

Figure 3: Examples of rope-and-pulley arrangements

In the ideal case the virtual work of the applied force P is equal to the one of the load Q . It should be noted, however, that in real systems the magnitude of the force P must be greater because of friction forces and other resistances. For example in the case of the simple pulley (Fig. 3a) its mechanical efficiency is of 97–99%.

2.3 Strain-gauge experimental analysis

Let us consider the rod loaded by two equal and opposite forces N and $-N$ (Fig. 4).

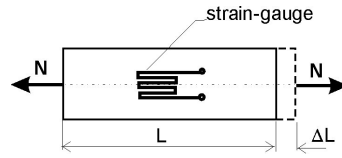

Figure 4: Uniaxial tension of the bar and a strain-gauge

If the rod is made from homogeneous, isotropic material its relative elongation (strain) is

$$\varepsilon = \frac{\Delta L}{L} = \frac{N}{EF} = \frac{\sigma}{E}, \quad (2)$$

where: ε – longitudinal strain of the bar, ΔL – elongation of the bar, L – length of the bar, N – magnitude of the axial force, F – area of the cross-section of the bar, E – Young’s modulus, σ – normal stress in the bar. The contact between the strain-gauge and the surface of the bar is assumed as ideal (there is no sliding of the gauge with respect to the bar surface). The variation of the resistance is produced by mechanical and thermal deformation of the bar:

$$\frac{\Delta R}{R} = \left(\frac{\Delta R}{R} \right)_{\varepsilon} + \left(\frac{\Delta R}{R} \right)_{T}. \quad (3)$$

The above-presented relationship (2) does not fully capture the deformation experienced by a real rod when loaded with axial forces. In addition to longitudinal deformation ε , such a rod also experiences transverse deformation with a sign opposite to ε . This means that a rod in tension will exhibit a reduction in its transverse dimensions as the applied force increases. The magnitude of these changes depends on Poisson’s ratio ν (for structural steels $\nu = 0.3$). A resistance strain gauge, a wire or foil resistor (see below), is attached to the tensioned rod. As the rod deforms, the strain gauge also undergoes deformation, changing its electrical resistance R by the value ΔR . For a given type of strain gauge (within the range of elastic deformations, i.e., the applicability of Hooke’s law), the following relationship holds:

$$\frac{\Delta R}{\varepsilon} = k. \quad (4)$$

where: k : strain sensitivity coefficient of the given strain gauge.

By measuring strain-induced resistance changes of the strain gauge and knowing its sensitivity coefficient k , one can determine the relative strain ε and then calculate the force in the rod. This force is defined by the relationship

$$N = EF\varepsilon. \quad (5)$$

Since the induced relative resistance changes are small (on the order of a *per mille*) and are comparable to the resistance changes caused by the influence of the ambient temperature, strain gauge systems (two or four) connected in a Wheatstone bridge configuration are used, Fig. 5.

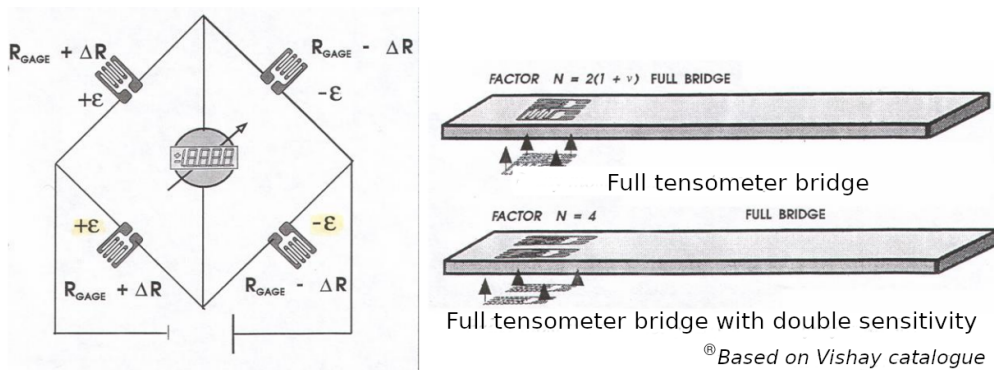

Figure 5: Tensometryczny mostek Wheatstone’a oraz sposób umieszczania tensometrów na pręcie

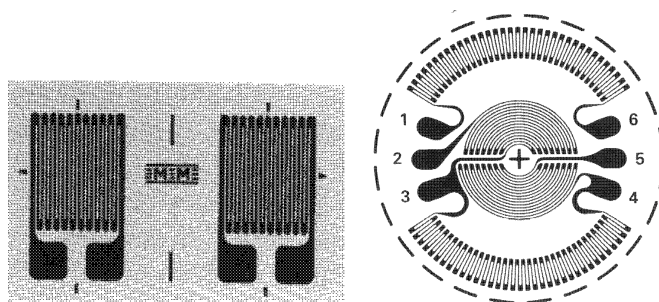

Figure 6: Examples of foil strain-gauges

Changes in the resistance of strain gauges connected to the bridge circuit cause voltage changes across the vertical diagonal of the bridge. Using an appropriately calibrated measuring amplifier allows for direct reading of the strain value ε or the strain increase relative to the initial state (this depends on the type of amplifier used).

A strain gauge amplifier can only interface with one strain gauge bridge (measuring point) at a time. To measure strain across multiple bridges, bridge switches, also known as switch boxes, are used. These enable strain measurements at a large number of points (in the case of trusses, across multiple members). Currently, bridges with digital outputs that can be connected to a PC are increasingly being used. This simplifies calculations and the analysis of experimental results, especially for very complex mechanical structures. Detailed instructions for using a specific type of amplifier are included in its user manual.

3 Description of the test rig

3.1 The rig

Fig. 7 shows a rig for testing forces in truss model elements. The rig consists of a steel frame (1), on which a truss (2) made of thin steel flat bars spans, connected by gusset plates (5). The truss is suspended from the frame using rods. It is loaded with pulleys (3) via a summing block (4). The tension rod is guided by fixed pulleys (7), which allow for varying the load applied to the truss. Placing weights on the pulley pan generates forces in the rods.

Strain gauges are attached to the truss rods, support rods, and auxiliary rods. Very thin wires are soldered to the bridge leads, the other ends of which are soldered to a connecting strip mounted on the upper crossbar of the stand frame.

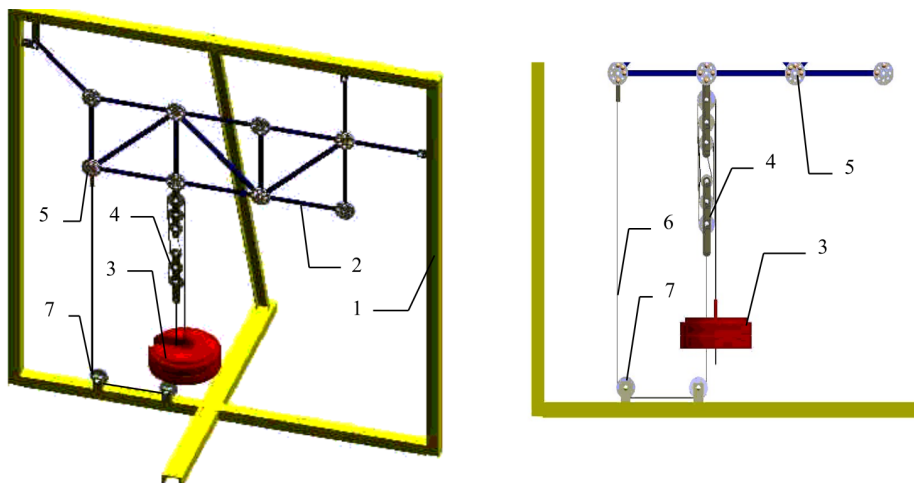

Figure 7: View of the experimental stand: truss model – left, cable-and-pulley arrangement – right

3.2 Measuring equipment

Strain-gauges bonded on opposite surfaces of bars (truss members) are used in order to determine internal forces in these members. The change of the gauge resistances is measured by the Wheatstone's bridge. The view of the measuring system is given on the Fig. 7. The method of reading depends on a type of a strain-gauge amplifier used. Changes in strain gauge resistance are measured by a strain gauge measuring amplifier. The measurement signal reaches it through a switch box, which allows for connection of selected strain gauges via a central switch (Fig. 8).



Figure 8: View of the measuring equipment

4 Experimental procedure

The computer program T_2.EXE helps understanding the method applied in solving equations and verifies students' results. Also calculates relative error compared to experimental measurements.

1. Choose numbers of bars to be tested and calculated, max. is 6 as only some of them are connected to the measurement device (1, 5, 8, 10, 12, 13). Also agree the variant of the external load (50 or 100 N).
2. Calculate loads P_1 and P_2 acting in the pulley block and reactions at points A and B.
3. Determine the forces in the tested truss members using the Ritter method.
4. For each of chosen bars apply the following procedure:
 - With the bridge OFF, select the appropriate strain gauge number using the rotary switch.
 - Turn on the bridge and zero the readings using the TARE button.
 - Apply the assumed load the (yellow weights). Read and record the force value in the bar from the bridge display. Place weights gently on the bottom of the pulley (it should remain stationary).
 - Select the bar number in the program and enter the measured force value. Based on the results provided by the program, verify the previously calculated force value in the bar and result measured. Record the relative measurement error.
 - Turn off the bridge and remove all the weights from the grid weighing pan except the red one.
5. Repeat the measurements (steps in p. 4) for another value of the weight.
6. Remove all loads yellow disks, switch off measurement device. Switch off the instruments and the computer.

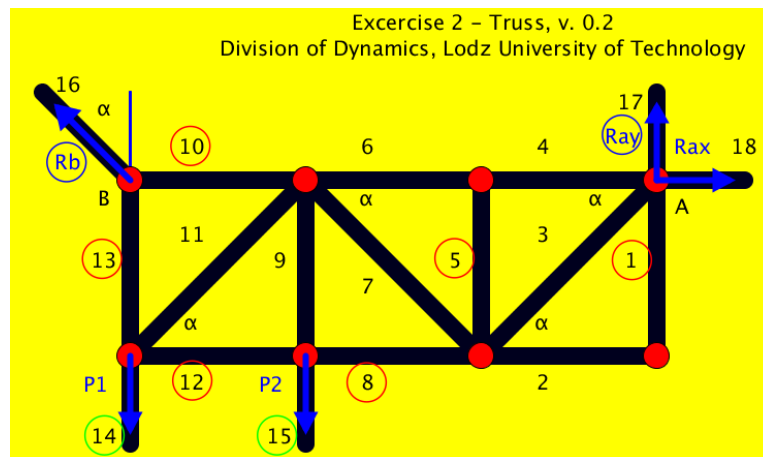

Figure 9: Numbering of truss bars, in circles elements connected to measurement device

5 Experimental results in final report

Relative differences P_i between experimental P_i and theoretical P_{it} results is calculated from the following expression

$$\delta_i = \frac{P_i - P_{it}}{P_{it}} 100\% \quad (6)$$

The report should include: results of the preliminary calculations, tables 1 and 2 with the experimental results and the calculations, analysis of truss by the method of section (Ritter's method), conclusions.

6 Questions (may be asked before test)

1. Give a definition of a truss and the force in the member.
2. Explain truss expressions: rigid and non-rigid, statically determinate and indeterminate.
3. Describe the method of joints and the method of section in the analysis of trusses.
4. Give examples of zero-force members.
5. Derive the basic formula for a strain-gauge (relating the strain and relative change of its resistance).
6. Explain the influence of the temperature on strain-gauge measurements.

LABORATORY OF MECHANICS

Exercise 2

DETERMINATION OF FORCES IN THE TRUSS MEMBERS

Group: _____

Date: _____

Team: _____

Student names:

1. _____
2. _____
3. _____
4. _____
5. _____
6. _____

Table 1: Preliminary calculations

a) For the weight $Q = 50\text{ N}$ applied on the pulley block (being in equilibrium) determine the tension of the cables S_1, S_2 .

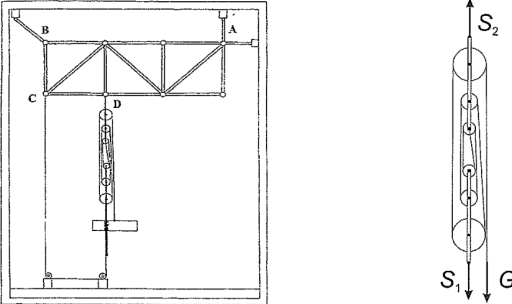
Free-body diagram	Equilibrium equations and its resolution
	

Numerical results for $Q = \dots$

$S_1 = \dots$

$S_2 = \dots$

b) Knowing the magnitudes of the forces S_1, S_2 compute the reactions at A and B.

Free-body diagram	Equilibrium equations and its resolution

numerical results: $R_{Ax} = \dots$

$R_B = \dots R_{Ay} = \dots$

Table 1: **Experimental and theoretical results for truss members**

Bar no.	Exp. force P_i	Theoretical force P_{id}	Relative difference P_i and P_{id}
i	[N]	[N]	Δ_i [%]
1			
5			
8			
10			
12			
13			

Force determination by the method of section (incl. free-body diagram, equations and numerical results)

Observations and conclusions